

Driver Unit 3055 XT

**LMT
100V**

Made in an Aluminum die cast head fitted with a spun aluminium back cover turning it to a weather resistant enclosure for an LMT (Line Matching Transformer) Driver unit. this high quality Ferrite magnet driver unit is fitted with a high quality rotatory switch enabling one to select the output from 5 watts to 50 watts in 5 steps and an off position. depending upon amplifier's power and/or number of units required to install can be optimally organized. 3055 XT 60 Watts driver unit is ideally suited to fit into any reflex or trumpet horn giving excellent frequency response, making it ideal for PA systems and outdoor playback. it is fitted with specially shaped phenolic diaphragms, which is precision wound on POLYIMIDE Film former. a special adhesive is added during winding, making it high temperature resistant.

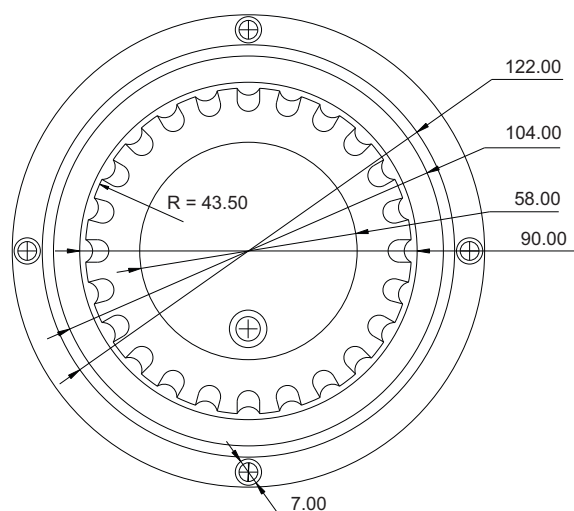
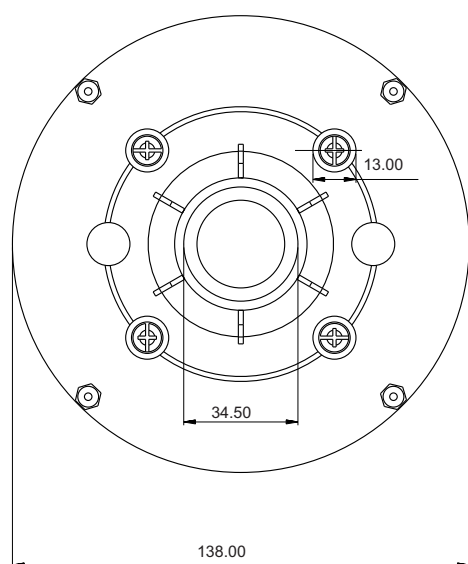

Technical Specifications of 3055 XT Driver Unit

Maximum Power	80/120 Watts
Rated Power	60/80 Watts
Throat Coupling	1-3/8" 18 TPI
T/f Voltage	100 V
Tappings	6,12,25,37,50 W
Frequency Response	200 - 7500 Hz
Voice Coil	2"
Head Cover	Die Cast Aluminium
Magnet	Ferrite
Weight	2225 gms